

# ALIANS ELBOWS.

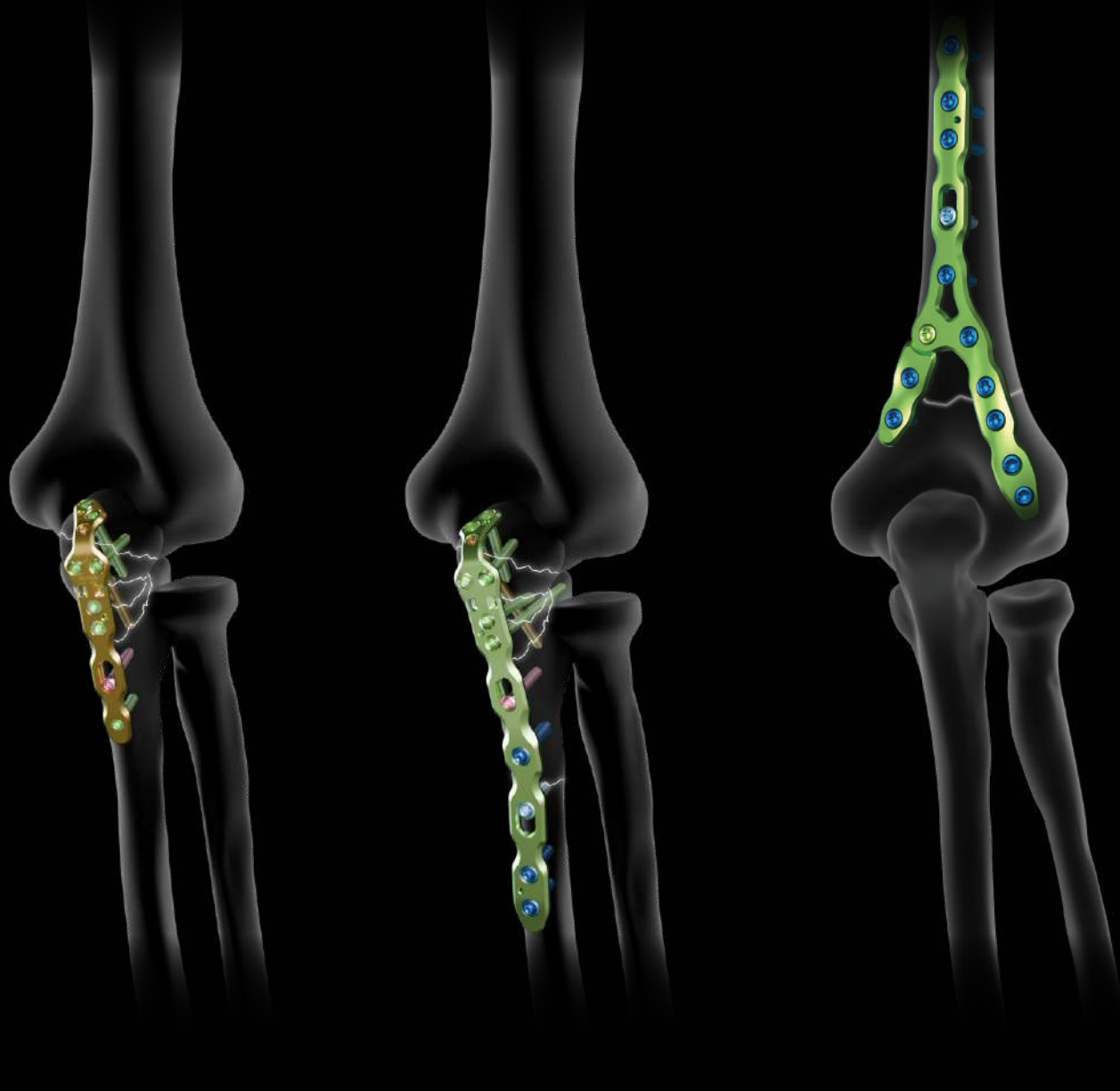

DISTAL HUMERUS  
& PROXIMAL  
ULNA PLATES





# Alians Elbow S.

## DISTAL HUMERUS & PROXIMAL ULNA PLATES

### **Intended purpose:**

The implants of the Alians Elbow S range are dedicated to the fixation of fractures and osteotomies of the distal humerus and proximal ulna in adults.

### **Contraindications:**

- Pregnancy.
- Acute or chronic local or systemic infections.
- Allergy to one of the materials used or sensitivity to foreign bodies.

# A comprehensive range of plates.

## DISTAL HUMERUS PLATES

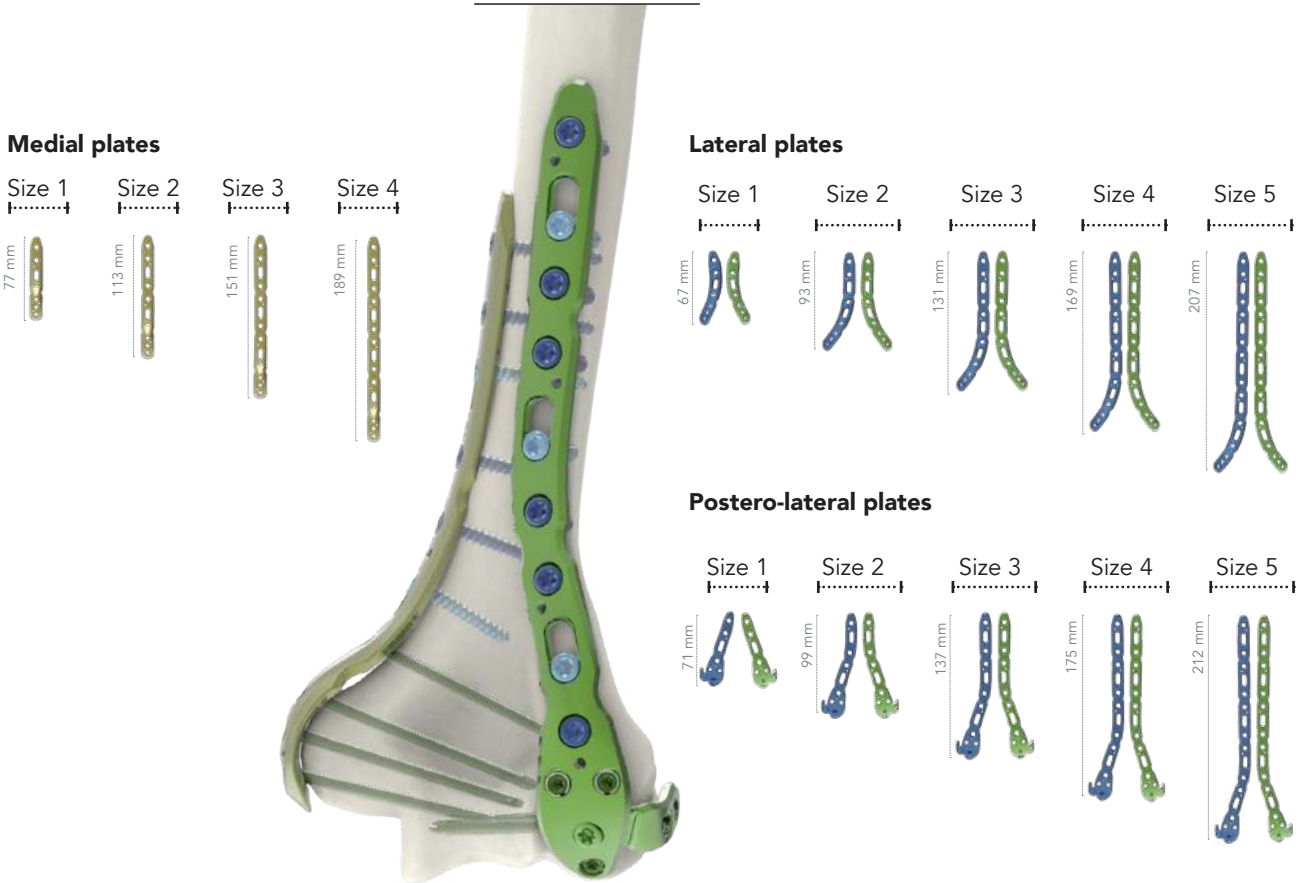

### PARALLEL CONSTRUCT

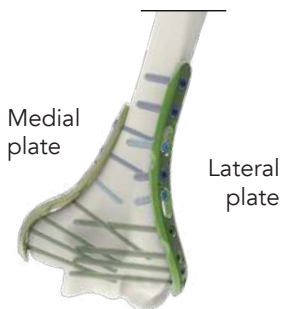

### PERPENDICULAR CONSTRUCT

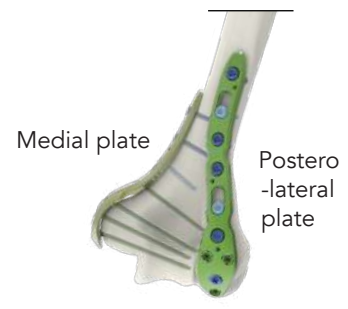
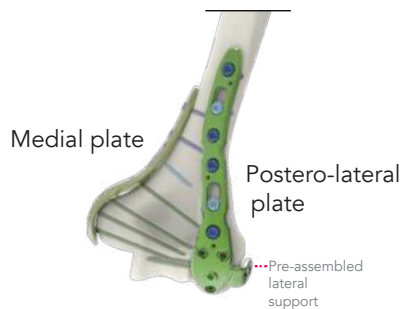

#### Fixation with lateral support

In the case of a perpendicular construct, the lateral support enables the insertion of 2 additional polyaxial screws through the articular block.

The construct is stabilized by these two screws running from the lateral column to the medial column.

#### Fixation without lateral support

Distal humerus postero-lateral plates can be fitted to several types of fractures. It is possible to remove the support in the case of isolated fractures of the capitellum or on very small humerus. In this case, a Ø3.5 mm locking screw can be inserted into the freed hole.

**DISTAL HUMERUS: Y PLATES**

**Y plates**

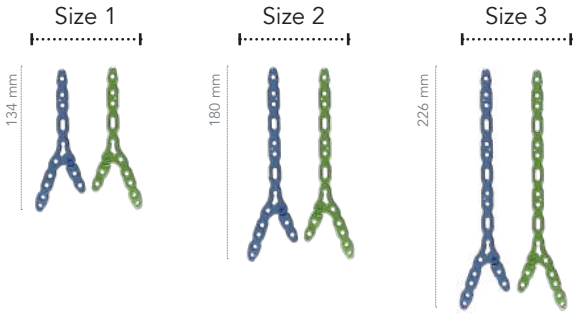

**OLECRANON PLATES**

**Standard plates**

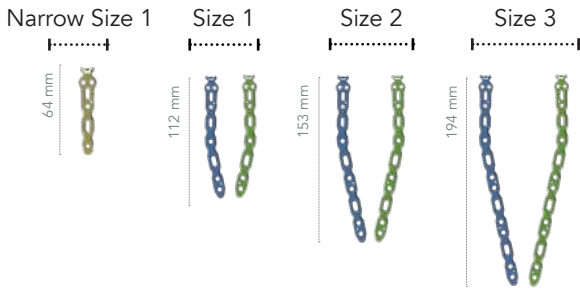

- Olecranon fractures
- Extra-articular fractures of the proximal ulna
- Osteotomies of the proximal ulna (following pseudarthrosis or vicious callus)

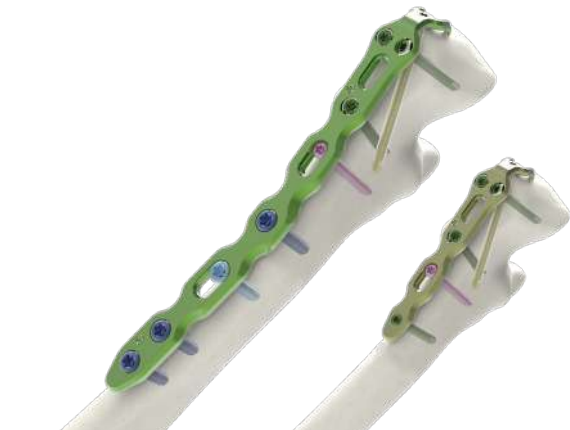

**Complex fractures plates**

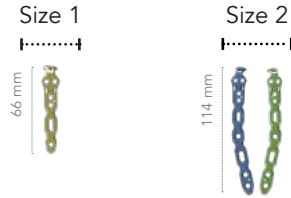

- Complex and comminuted fractures of the proximal olecranon
- Extra-articular fractures of the proximal ulna
- Osteotomies of the proximal ulna (following pseudarthrosis or vicious callus)

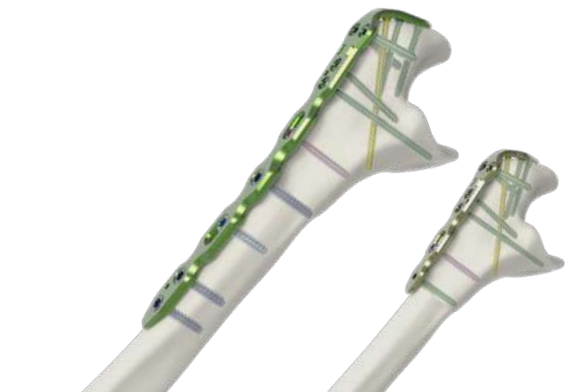

# Technical features.

## PRECONTOURED IMPLANTS

### OPTIMIZED ANATOMICAL CONGRUENCE

Resulting from an original design technique based on bone surface modeling, this generation of implants benefits from optimized anatomical congruence between the plate and the bone.



### BENDABLE PLATES

The plates from the Alians Elbow S range offer bending areas. In certain cases, it is possible to bend the plate using the bending irons (ANC650) following the instructions below:

- Bending is only possible in the areas intended for this purpose.
- A bendable area should be bent only once and in one direction.
- Bending should not be performed excessively.
- There is a risk of distortion of the holes when bending the plate. Thus, the holes must be protected to avoid damaging the fixation system.

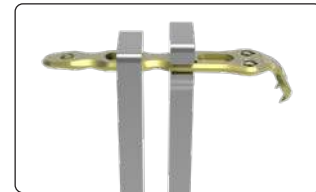

## POLYAXIAL LOCKING FIXATION

Polyaxial locking fixation gives the surgeon the ability to reach bone fragments in different directions. It also allows to avoid conflicts between screws from another plate.

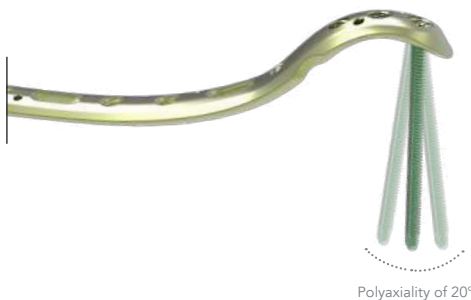

The DTS3 technology ensures the locking of the screw into the plate while allowing its angulation. This system facilitates the insertion of screws in diverging or converging directions, improving the stability of the assembly.



Dualtec System® III Technology  
Polyaxial locking fixation

## MONOAXIAL LOCKING SYSTEM

- The screw head is stopped in the hole, ensuring its locking.
- The screw head is buried in the plate.
- Plate and screw made from the same material: titanium alloy.
- Non locking screws (CT2.8LxD or CT3.5LxD according to the hole diameter) can be used in the locking holes at the surgeon's discretion.

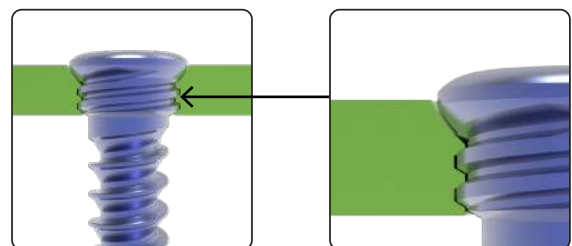

The threads under the screw head and inside the hole have strictly the same characteristics.

## DISTAL HUMERUS: MEDIAL, LATERAL AND POSTERO-LATERAL PLATES

### Medial Plates

- Medial column
- Medial position
- Medio-lateral direction of the distal screws
- Rounded shape and smooth edges

### Lateral plates

- Lateral column
- Lateral position
- Latero-medial direction of the distal screws
- Rounded shape and smooth edges

### Postero-lateral plates

- Lateral column
- Dorsal position
- Postero-anterior and latero-medial direction of the distal screws
- Lateral pre-assembled support (see page 8 for more information)
- Rounded shape and smooth edges

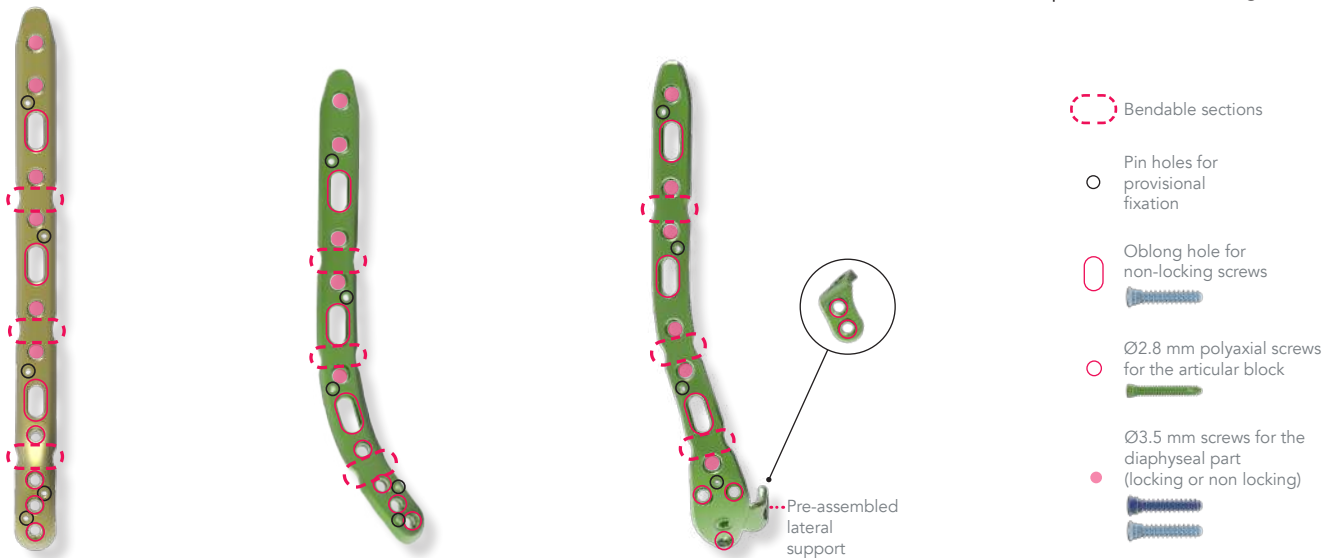

## POLYAXIAL FIXATION: TWO-PLATE CONSTRUCT

### Locking polyaxial fixation:

- Allows the surgeon to reach all fragments of the articular block using long screws.
- Avoids conflicts between screws in the articular block.

### Medial plate

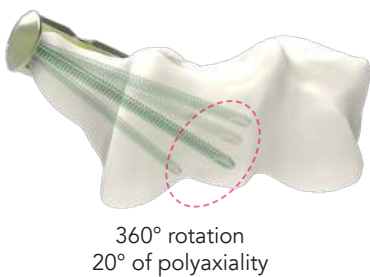

### Lateral plate

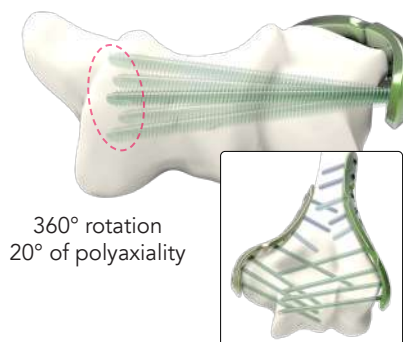

### Postero-lateral plate

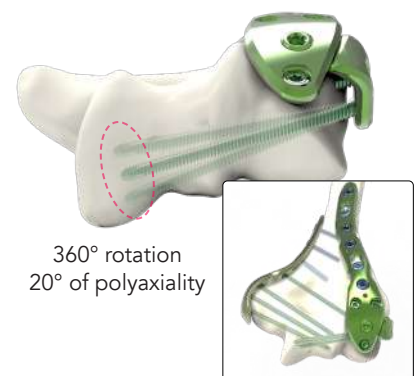

## DISTAL HUMERUS: Y PLATES

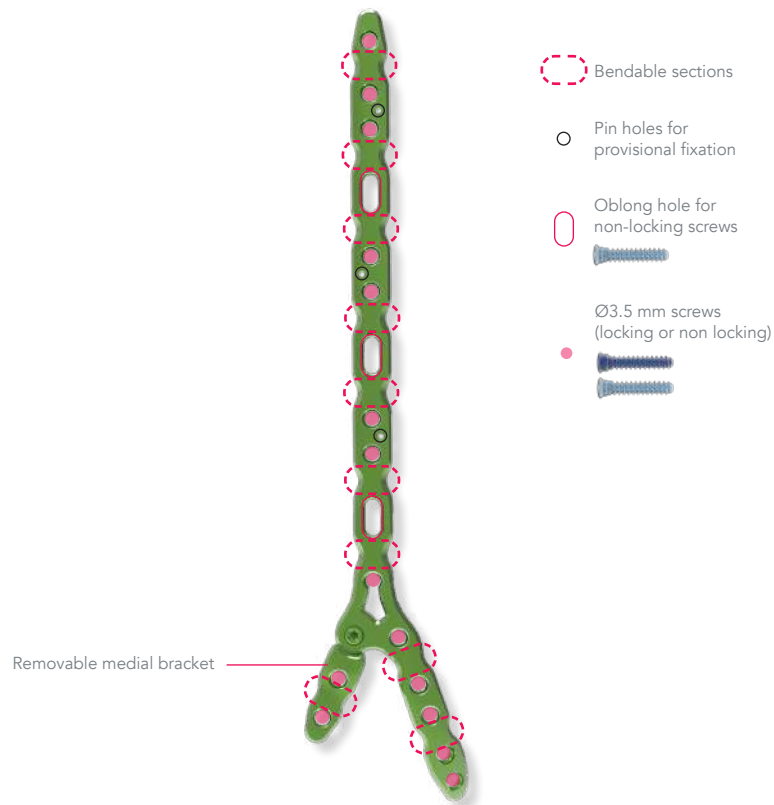

- Plate designed for extra-articular fractures.
- Rounded shape and smooth edges
- The Y shape allows both medial and lateral columns to be supported by only one plate.
- Single diameter 3.5 mm for all screws.
- Removable medial bracket to adapt to different fractures patterns and patient anatomy (see page 8 for more information).



# OLECRANON PLATES

## PRECONTOURED IMPLANTS

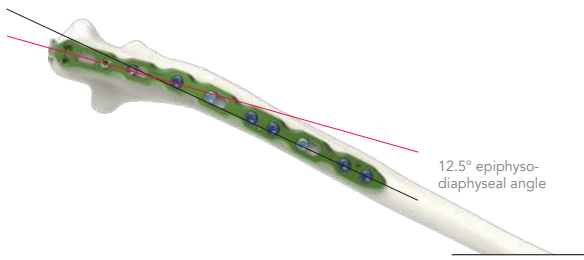

The olecranon plates of the Alians Elbow S range have been designed on the basis of osteological studies of the olecranon. The design of the plate adapts to the olecranon epiphysio-diaphyseal curve.

The anatomical design of the plate and the buried screw heads are designed in the intention of limiting soft tissue irritation.

“Home run” screw oriented towards the base of the coronoid and crossing the fracture site to improve stability or create compression



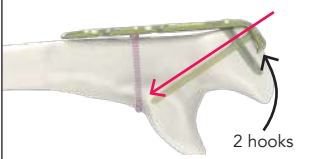

Home run screw





2 hooks

**Narrow plate**

**Standard plates**

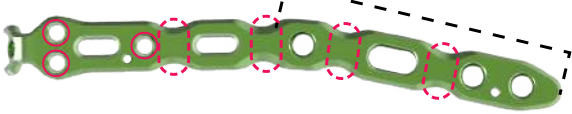



Polyaxial holes



2 olecranon screws:  
The screws are directed towards the tip of the olecranon.

Polyaxial hole



Coronoid screw:  
The coronoid screw allows the stabilization of the coronoid.

## POLYAXIAL LOCKING FIXATION

### Complex fracture plates

“Home run” screw oriented towards the base of the coronoid and crossing the fracture site to improve stability or create compression



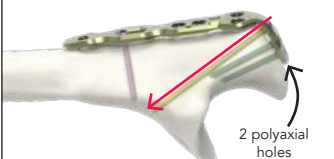

Home run screw





2 polyaxial holes

Addition of 2 polyaxial holes Ø2.8 mm to reach extra-proximal fragments for locking screw TDT2.8LxxD or non-locking screw RDT2.8LxxD.

**Narrow plate**





**Standard plates**







Bendable sections





Ø2.8 mm polyaxial screws for the articular block





Ø2.8 mm locking or non locking screw for the diaphyseal part





The suture holes are compatible with Ø1.2 mm needles for proximal olecranon plates. We recommend the use of sutures #1 USP (4 Ph. Eur.).



Diaphyseal implant reinforcement + Ø3.5 mm screws for the diaphyseal part (locking or non locking)



# Instrumentation.

## MEASURING SCREW LENGTHS

For all the holes of the Alians Elbow S range, the measurement of a screw length can be obtained in the following 2 ways:

- During drilling, by reading the length directly on the guide gauge using the laser marking on the drill bit<sup>(a)</sup>
- Using the appropriate length gauge after drilling<sup>(b)</sup>

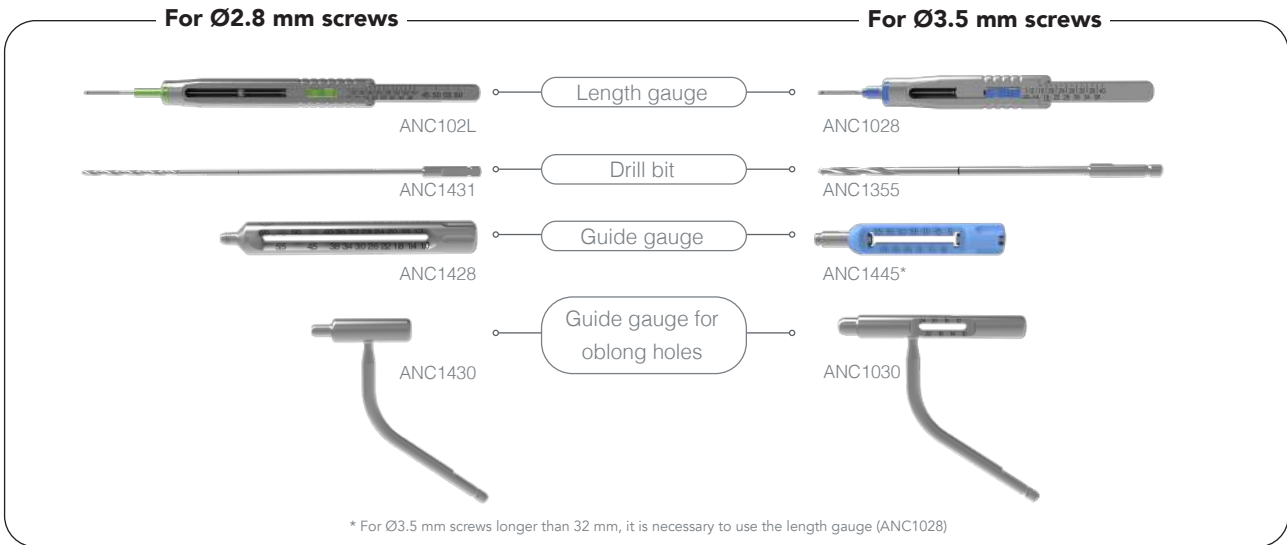
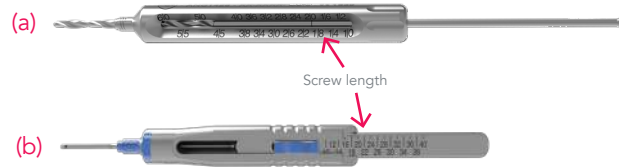

## DRILLING GUIDES

For all the Ø2.8 locking holes of the Alians Elbow S range, the drilling can be performed using two different drill guides:

- ANC1428 - Ø2.0 mm long threaded guide gauge<sup>(c)</sup> : screw length can be read directly during drilling
- ANC1429 - Ø2.0 mm threaded drill guide<sup>(d)</sup> : screw length must be measured with the length gauge (ANC102L)



## REMOVABLE SUPPORTS

The Alians Elbow S range offers plates with removable supports. Depending on the indications and the anatomy of the patient, these brackets can be removed with the T15 screwdriver (ANC1027)<sup>(e)</sup>.



### Y plate:

The Y plate offers a removable medial support allowing to support the medial column of the distal humerus.



### Postero-lateral plate:

The postero-lateral plate offers a removable lateral support, allowing the insertion of 2 additional polyaxial long screws in the articular block. These two screws extend from the lateral column to the medial column of the distal humerus.

# Surgical technique.

## DISTAL HUMERUS – 2-PLATE CONSTRUCT : MEDIAL PLATE

(PAGE 1/2)

Example of a surgical technique using a medial plate size 1 (NTSM1D).  
This technique is applicable for both perpendicular and parallel constructs. The finalization of the fixation of the medial plate occurs after the fixation of the second plate.



1 After reduction of the distal humerus, position the plate on the medial part of the bone. The plate can be provisionally fixed using Ø1.6 mm pins (33.0216.210).



2 In one of the oblong holes, perform the drilling using the non threaded bent guide gauge (ANC1030) and the Ø2.7 mm drill bit (ANC1355).

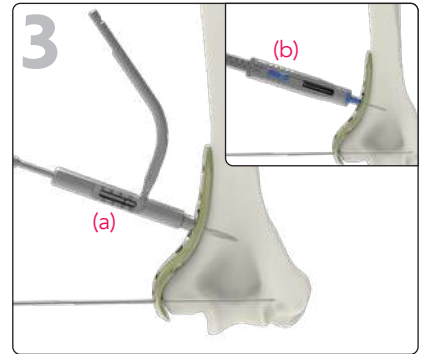

3 Measure the screw length directly on the guide gauge (ANC1030)<sup>(a)</sup> or with the length gauge (ANC1028)<sup>(b)</sup>.

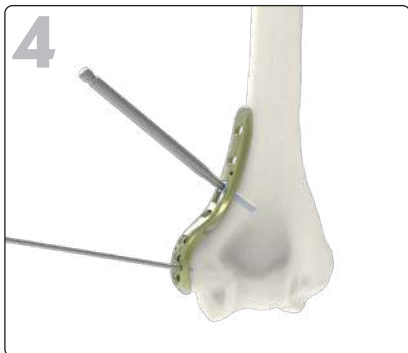

4 Insert a Ø3.5 mm locking screw (CT3.5LxxD) using the T15 screwdriver (ANC1027).

Repeat the steps 2 to 4 for the remaining oblong holes.

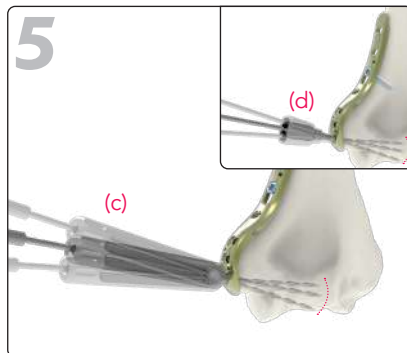

5 The distal holes of the plates allow for polyaxial fixation of the screws.

Insert the Ø2.0 mm threaded long guide gauge (ANC1428) into one of the distal holes. If needed, angulate as required and perform the drilling using the Ø2.0 mm drill bit (ANC1431)<sup>(c)</sup>.

Option: a shorter threaded drill guide (ANC1429) can be used to guide the drill bit<sup>(d)</sup>.

Repeat these steps for all the remaining distal screws.



6 Measure the screw length directly on the guide gauge (ANC1428)<sup>(e)</sup> or with the length gauge (ANC102L)<sup>(e)</sup>.

Option: if the shorter drill guide (ANC1429) was used, the use of the length gauge is mandatory to measure the screw length.

## DISTAL HUMERUS – 2-PLATE CONSTRUCT : MEDIAL PLATE

(PAGE 2/2)



Insert a  $\varnothing 2.8$  mm locking screw (TDT2.8LxD) using the T8 screwdriver (ANC575).



Repeat these steps for the remaining distal holes.

### TO FINALIZE THE CONSTRUCT



With a lateral plate for a parallel construct refer to page 12.



With a postero-lateral plate for a perpendicular construct refer to page 14.

# DISTAL HUMERUS – PARALLEL CONSTRUCT: LATERAL PLATE

(PAGE 1/2)

Example of a surgical technique using a medial plate size 1 (NTSM1D).  
 This technique is applicable for both perpendicular and parallel constructs. The finalization of the fixation of the medial plate occurs after the fixation of the second plate.

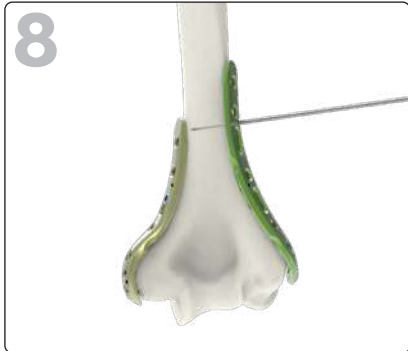

Position the lateral plate on the lateral part of the bone. The plate can be provisionally fixed using Ø1.6 mm pins (33.0216.210).



In one of the oblong holes, perform the drilling using the threaded bent guide gauge (ANC1030) and the Ø2.7 mm drill bit (ANC1355).

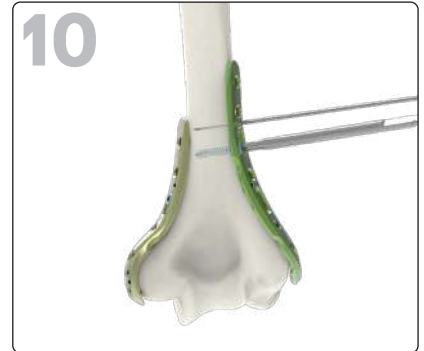

Measure the screw length (see details on page 10 step 3).

Insert a Ø3.5 mm non locking screw (CT3.5LxxD) using the T15 screwdriver (ANC1027).

Repeat the steps 9 and 10 for the remaining oblong holes.



The distal holes of the plates allow for polyaxial fixation of the screws.

Insert the Ø2.0 mm threaded guide gauge (see details on page 10 step 5) into one of the distal holes. If needed, angulate as required and perform the drilling using the Ø2.0 mm drill bit (ANC1431).



Measure the screw length (see details on page 10 step 6).

Insert a Ø2.8 mm locking screw (TDT2.8LxxD) using the T8 screwdriver (ANC575).

Repeat these steps for all the remaining distal holes.

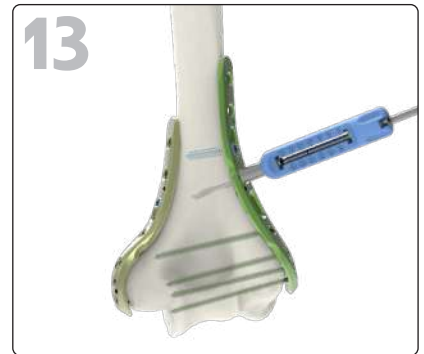

In the first diaphyseal locking hole, perform the drilling using the threaded guide gauge (ANC1445) and the Ø2.7 mm drill bit (ANC1355).

## DISTAL HUMERUS – PARALLEL CONSTRUCT: LATERAL PLATE

(PAGE 2/2)

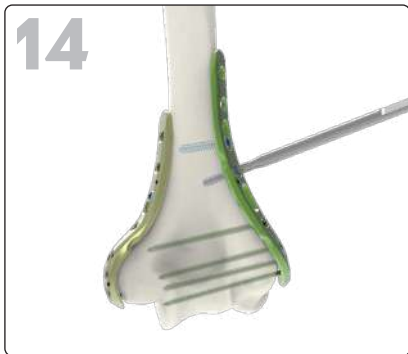

Measure the screw length (see details on page 10 step 3).

Insert a  $\text{\O}3.5$  mm locking screw (SOT3.5LxD) using the T15 screwdriver (ANC1027).

To finalize the procedure, repeat the steps 13 and 14 by inserting the remaining  $\text{\O}3.5$  mm locking screws (SOT3.5LxD) into the diaphyseal part of the medial and lateral plates, going distally to proximally.



**FINAL  
RESULT.**

# DISTAL HUMERUS – PERPENDICULAR CONSTRUCT: POSTERO-LATERAL PLATE (PAGE 1/2)

Example of a surgical technique using a medial plate size 1 (NTSM1D) and a postero-lateral plate size 2 (NTDQ2D) for a perpendicular construct. This technique is applicable for all medial and postero-lateral plates.

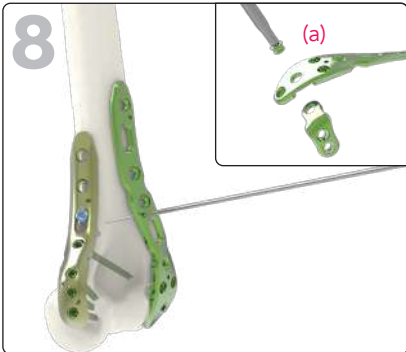

Position the posterolateral plate on the posterior part of the bone. The plate can be provisionally fixed using Ø1.6 mm pins (33.0216.210).

Option: In cases for which the lateral support is not required, this part of the plate can be removed using the T15 screwdriver (ANC1027)<sup>(a)</sup>. If so, a Ø3.5 mm locking screw can be inserted in the free locking hole.



In one of the oblong hole, perform the drilling using the non threaded bent guide gauge (ANC1030) and the Ø2.7 mm drill bit (ANC1355).



Measure the screw length (see details on page 10).

Insert a Ø3.5 mm non locking screw (CT3.5LxxD) using the T15 screwdriver (ANC1027).

Repeat the steps 9 et 10 for the remaining oblong holes.



The distal holes of the plate allow for polyaxial fixation of the screws.

Insert Ø2.0 mm threaded guide gauge (see details on page 10 step 5) into one of the distal holes. If needed, angulate as required and perform the drilling using the Ø2.0 mm drill bit (ANC1431).

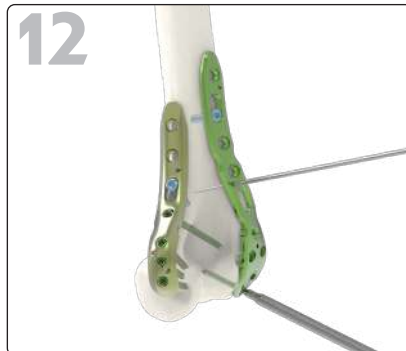

Measure the screw length (see details on page 10 step 6).

Insert a Ø2.8 mm locking screw (TDT2.8LxxD) using the T8 screwdriver (ANC575).

Repeat these steps for the remaining distal locking holes.

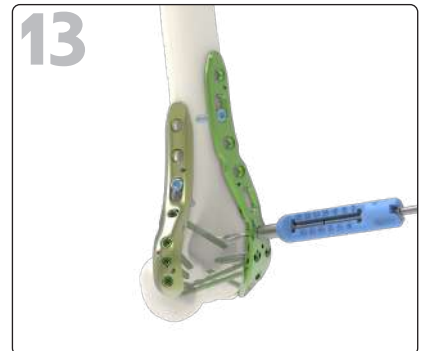

In the first diaphyseal locking hole, perform the drilling using the threaded guide gauge (ANC1445) and the Ø2.7 mm drill bit (ANC1355).

## DISTAL HUMERUS – PERPENDICULAR CONSTRUCT: POSTERO-LATERAL PLATE (PAGE 2/2)



Measure the screw length (see details on page 10 step 3).

Insert a  $\varnothing 3.5$  mm locking screw (SOT3.5LxD) using a T15 screwdriver (ANC1027).

Option: If the lateral support has been removed, repeat the steps 13 and 14 for the free distal hole.

To finalize the procedure, repeat the steps 13 and 14 by inserting the remaining  $\varnothing 3.5$  mm locking screws (SOT3.5LxD) into the diaphyseal part of the medial and postero-lateral plates, going distally to proximally.



**FINAL  
RESULT.**

# DISTAL HUMERUS - Y PLATE

Example of a surgical technique using a Y plate size 3 (NTDY3D). This technique is applicable for all the Y plates.

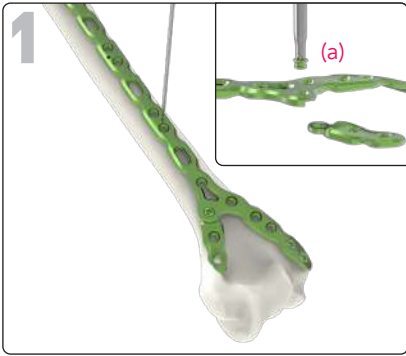

Position the Y plate on the posterior part of the bone. The plate can be provisionally fixed using Ø1.6 mm pins (33.0216.210).

Option: In cases for which the lateral support is not required, this part of the plate can be removed using the T15 screwdriver (ANC1027)<sup>(a)</sup>. If so, a Ø3.5 mm locking screw can be inserted into the free locking hole.

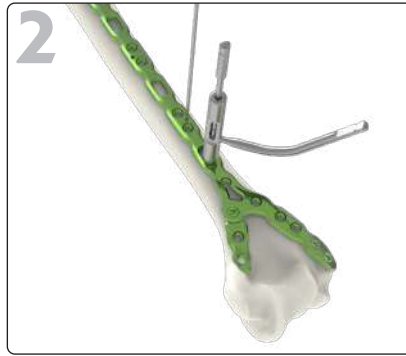

In a oblong hole, perform the drilling using the non threaded bent guide gauge (ANC1030) and the Ø2.7 mm drill bit (ANC1355).

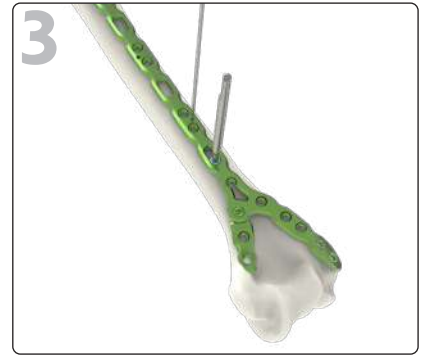

Measure the screw length (see details on page 10 step 3).

Insert a Ø3.5 mm non locking screw (CT3.5LxxD) using the T15 screwdriver (ANC1027).

Repeat the steps 2 and 3 for the remaining oblong holes.

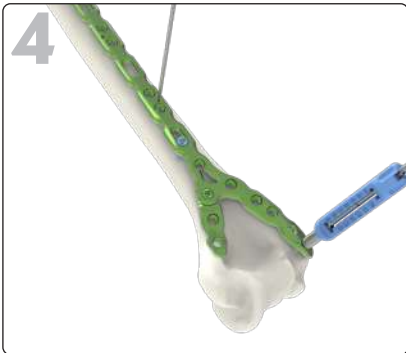

In the most distal locking hole of the lateral column, perform the drilling using the threaded guide gauge (ANC1445) and the Ø2.7 mm drill bit (ANC1355).

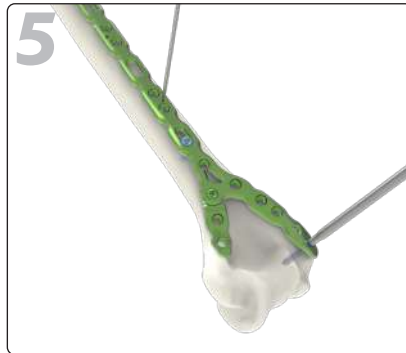

Measure the screw length (see details on page 10 step 3).

Insert a Ø3.5 mm locking screw (SOT3.5LxxD) using a T15 screwdriver (ANC1027).

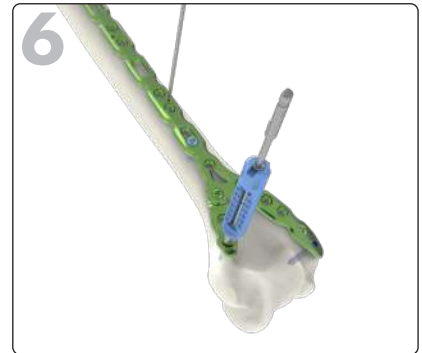

Proceed similarly for the most distal screw of the medial column.

Option: If the lateral support has been removed, repeat steps 4 and 5 for the free locking hole.

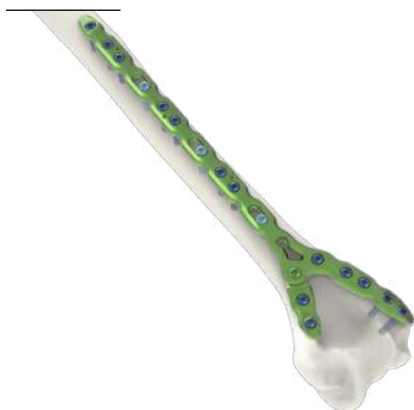

## FINAL RESULT.

Following the steps 4 and 5, finalize the procedure by inserting the remaining Ø3.5 mm locking screws (SOT3.5LxxD), starting with the screws closest to the fracture line and continue outwards.

# OLECRANON - OLECRANON OSTEOTOMY GUIDE

## SPECIFIC CUTTING GUIDE FOR OLECRANOTOMY

The olecranon cutting guide (ANC1432) is used to make the cuts **required for an olecranotomy approach**.

The olecranon cutting guide allows the adjustment of the chevron cut in 4 positions. It also allows the olecranon to be pre-drilled for subsequent anatomical reduction using the narrow plate (HTSPN1D).

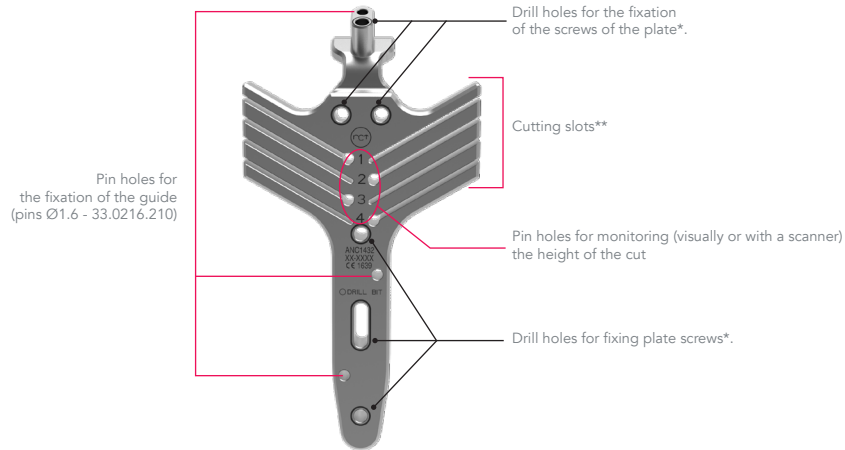

\*Drill holes for fixing the screws are marked with a black outline: DRILL BIT   
 \*\*Blade dimensions: 10mm wide and 0.5 +/- 0.05 thick

## SURGICAL TECHNIQUE

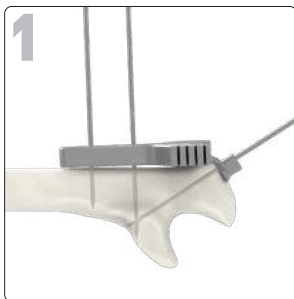

1 Fix the cutting guide.

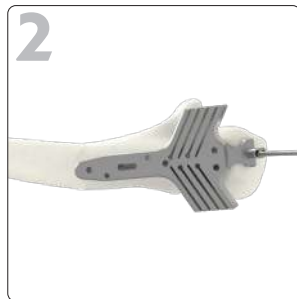

2 Cutting stage: the choice of the cutting height can be adjusted using the different slots in the guide.

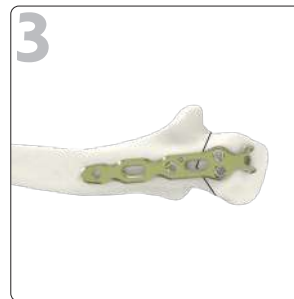

3 Position the plate (HTSPN1D) according to the pre-drilled holes.



**FINAL RESULT.**

## OLECRANON – NARROW PLATE (PAGE 1/2)

Example of a surgical technique using a narrow olecranon plate (HTSPN1D).  
This technique is applicable to the proximal olecranon complex fractures narrow plate.



1 Position the plate on the olecranon process. The plate can be temporarily fixed using Ø1.6 mm pins (33.0216.210).

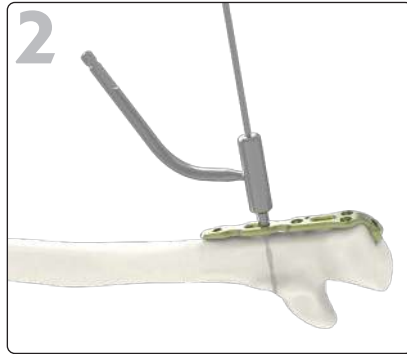

2 In the most distal Ø2.8 mm oblong hole, drill using the bent unthreaded guide gauge (ANC1430) and the Ø2.0 mm drill bit (ANC1431).

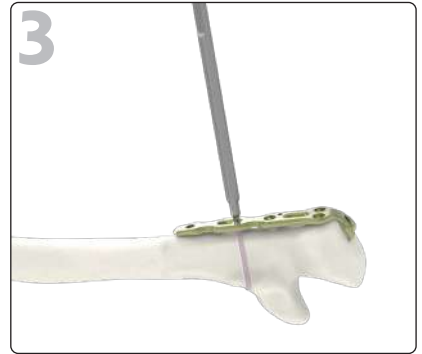

3 Measure the screw length with the length gauge (ANC102L) (see details on page 10 step 6).

Insert a Ø2.8 mm non locking screw (CT2.8LxxD) using the T8 screwdriver (ANC575).



4 **"Home run" screw**  
Insert the Ø2.0 mm threaded guide gauge (see details page 10) into the monoaxial hole. Perform the drilling with the Ø2.0 mm drill bit (ANC1431).

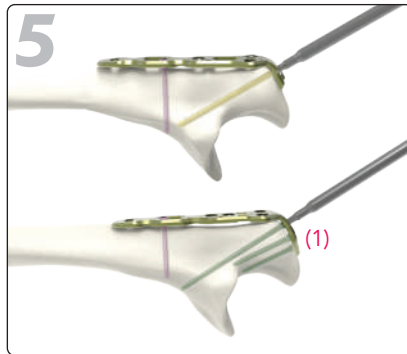

5 Measure the screw length (see details on page 10).

Insert a Ø2.8 mm non locking screw (RDT2.8LxxD) into the base of the coronoid process using the T8 screwdriver (ANC575) to apply compression.

If compression is not required, a Ø2.8 mm locking screw (TDT2.8LxxD) can be inserted instead.

<sup>(1)</sup>Example of screws positioning with an HTSEPS1D olecranon plate for the complex fractures.



6 The two distal polyaxial holes allow to target the tip of the olecranon.

Insert the Ø2.0 mm threaded guide gauge (see details on page 10) in one of the most proximal polyaxial holes and perform the drilling using the Ø2.0 mm drill bit (ANC1431).

To avoid conflict with the "Home run" screw, angulate the drilling in a divergent way.

## OLECRANON – NARROW PLATE (PAGE 2/2)

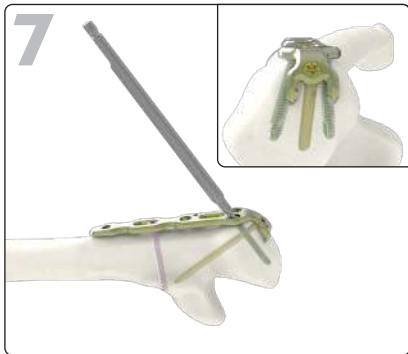

Measure the screw length (see details on page 10 step 6).

Insert a Ø2.8 mm locking screw (TDT2.8LxxD) using the T8 screwdriver (ANC575).

Repeat the step 6 for the second polyaxial screw.

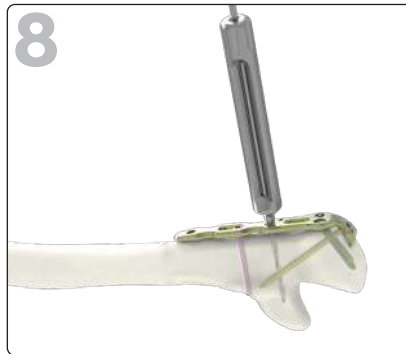

### Coronoid screw

Insert the Ø2.0 mm threaded guide gauge (ANC1428) (see details on page 10 step 5) in one of the polyaxial holes. If necessary, orientate the guide in order to both target the coronoid tip and avoid any conflict with the “home run” screw.

Perform the drilling using a Ø2.0 mm drill bit (ANC1431).

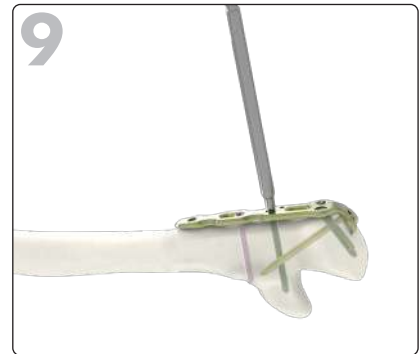

Measure the screw length (see details on page 10 step 6).

Insert a Ø2.8 mm locking screw (TDT2.8LxxD) using the T8 screwdriver (ANC575).



Insert the Ø2.0 mm threaded guide gauge (see details page 10 step 5) in the remaining monoaxial distal hole and perform the drilling using the Ø2.0 mm drill bit (ANC1431).

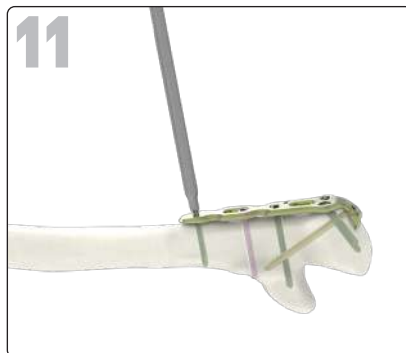

Measure the screw length (see details on page 10 step 6).

Insert a Ø2.8 mm locking screw (TDT2.8LxxD) using a T8 screwdriver (ANC575).

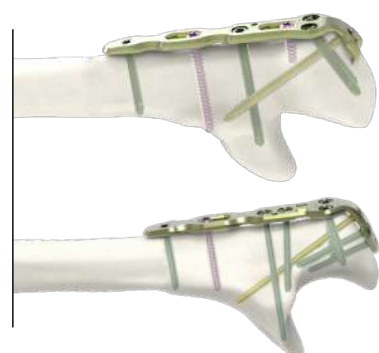

## FINAL RESULTS.

If the fracture line allows, finalize the construct by inserting a non locking screw (CT2.8LxxD) into the most proximal oblong hole (following the technique in steps 2 and 3).

# OLECRANON – STANDARD PLATE

Example of a surgical technique using a standard olecranon plate size 3 (HTDPS3D).



The surgical technique for standard olecranon plates is strictly identical to the one for narrow plates for the proximal part.

For the distal part, Ø3.5 mm screw must be used.

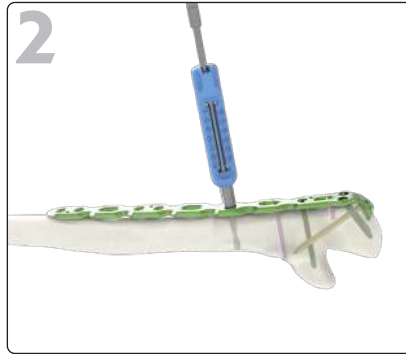

In the most proximal Ø3.5 mm locking hole, perform the drilling using threaded guide gauge (ANC1445) and the Ø2.7 mm drill bit (ANC1355).

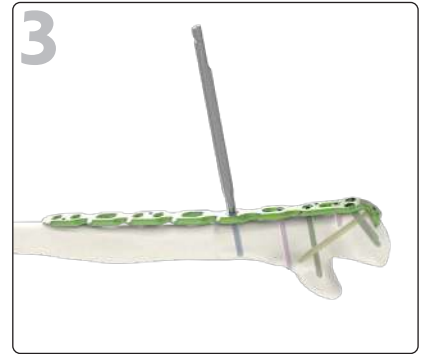

Measure the screw length (see details on page 10 step 3).

Insert a Ø3.5 mm locking screw (SOT3.5LxxD) using the T15 screwdriver (ANC1027).

Repeat the steps 13 and 14 for the remaining locking holes.

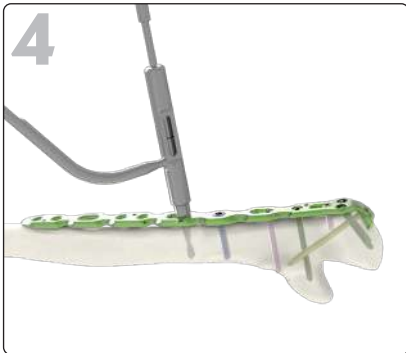

In the proximal Ø3.5 mm oblong hole, perform the drilling using the non threaded bent guide gauge (ANC1030) and the Ø2.7 mm drill bit (ANC1355).

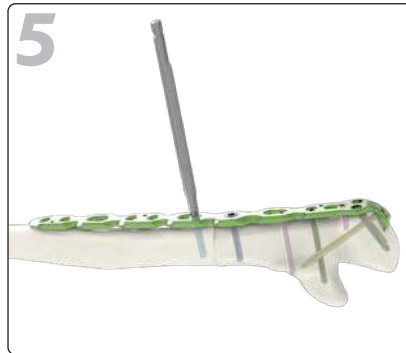

Measure the screw length (see details on page 10 step 3).

Insert a Ø3.5 mm non locking screw (CT3.5LxxD) using the T15 screwdriver (ANC1027).

Repeat the steps 15 et 16 for the remaining oblong holes.

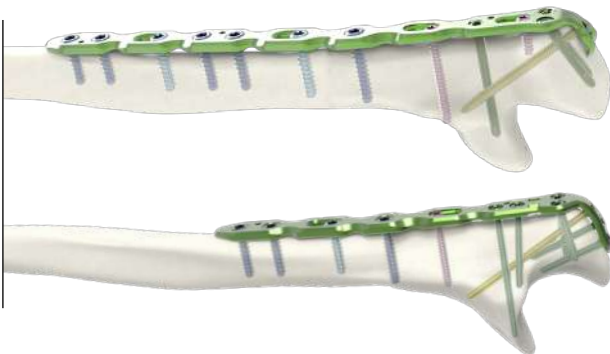

**FINAL RESULTS.**

# Implants references.

## DISTAL HUMERUS PLATES

### Medial plates

Ref.	Description
NTSM1D	Medial distal humerus plate - Symmetrical - Size 1 - 7 holes - L77 mm
NTSM2D	Medial distal humerus plate - Symmetrical - Size 2 - 10 holes - L113 mm
NTSM3D	Medial distal humerus plate - Symmetrical - Size 3 - 13 holes - L151 mm
NTSM4D	Medial distal humerus plate - Symmetrical - Size 4 - 16 holes - L189 mm

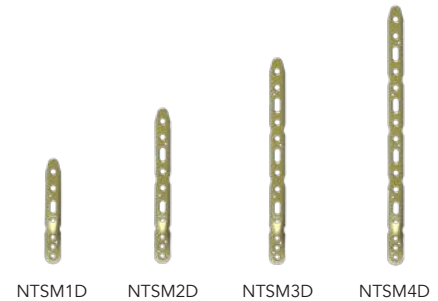

### Lateral plates

Ref.	Description
NTGL1D	Lateral distal humerus plate - Left - Size 1 - 7 holes - L67 mm
NTDL1D	Lateral distal humerus plate - Right - Size 1 - 7 holes - L67 mm
NTGL2D	Lateral distal humerus plate - Left - Size 2 - 9 holes - L93 mm
NTDL2D	Lateral distal humerus plate - Right - Size 2 - 9 holes - L93 mm
NTGL3D	Lateral distal humerus plate - Left - Size 3 - 12 holes - L131 mm
NTDL3D	Lateral distal humerus plate - Right - Size 3 - 12 holes - L131 mm
NTGL4D	Lateral distal humerus plate - Left - Size 4 - 15 holes - L169 mm
NTDL4D	Lateral distal humerus plate - Right - Size 4 - 15 holes - L169 mm
NTGL5D-ST*	Lateral distal humerus plate - Left - Size 5 - STERILE - 18 holes - L207 mm
NTDL5D-ST*	Lateral distal humerus plate - Right - Size 5 - STERILE - 18 holes - L207 mm

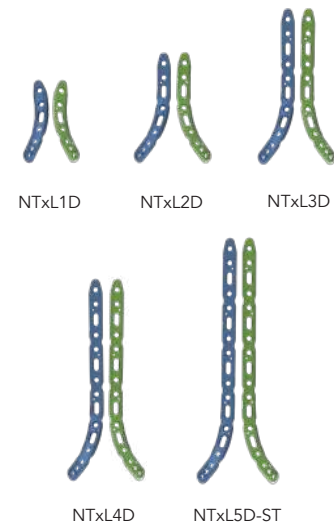

### Postero-lateral plates

Ref.	Description
NTGQ1D	Posterolateral distal humerus plate - Left - Size 1 - 9 plots - L71 mm
NTDQ1D	Posterolateral distal humerus plate - Right - Size 1 - 9 plots - L71 mm
NTGQ2D	Posterolateral distal humerus plate - Left - Size 2 - 11 plots - L99 mm
NTDQ2D	Posterolateral distal humerus plate - Right - Size 2 - 11 plots - L99 mm
NTGQ3D	Posterolateral distal humerus plate - Left - Size 3 - 14 plots - L137 mm
NTDQ3D	Posterolateral distal humerus plate - Right - Size 3 - 14 plots - L137 mm
NTGQ4D	Posterolateral distal humerus plate - Left - Size 4 - 17 plots - L175 mm
NTDQ4D	Posterolateral distal humerus plate - Right - Size 4 - 17 plots - L175 mm
NTGQ5D-ST*	Posterolateral distal humerus plate - Left - Size 5 - STERILE - 20 plots - L212 mm
NTDQ5D-ST*	Posterolateral distal humerus plate - Right - Size 5 - STERILE - 20 plots - L212 mm

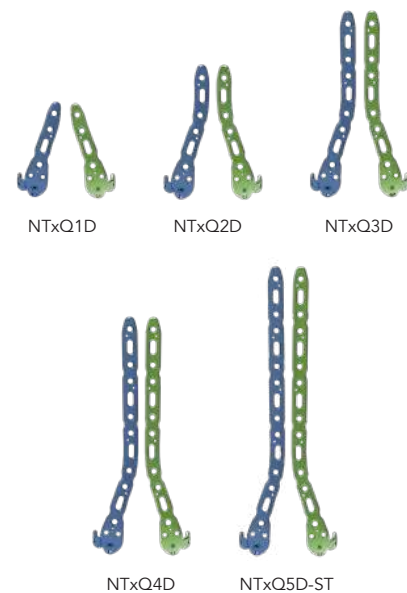

\* Only available in sterile version on request

# DISTAL HUMERUS PLATES

## Y plates

Ref.	Description
NTGY1D	Y distal humerus plate - Left - Size 1 - 12 holes - L134 mm
NTDY1D	Y distal humerus plate - Right - Size 1 - 12 holes - L134 mm
NTGY2D	Y distal humerus plate - Left - Size 2 - 15 holes - L180 mm
NTDY2D	Y distal humerus plate - Right - Size 2 - 15 holes - L180 mm
NTGY3D	Y distal humerus plate - Left - Size 3 - 18 holes - L226 mm
NTDY3D	Y distal humerus plate - Right - Size 3 - 18 holes - L226 mm

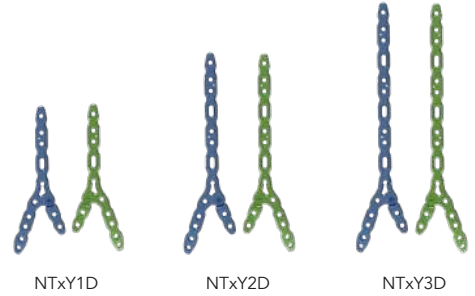

# OLECRANON PLATES

## Standard plates (with hook)

Ref.	Description
HTSPN1D	Olecranon plate - Narrow - Symmetrical - Size 1 - 7 holes - L64 mm
HTGPS1D	Olecranon plate - Standard - Left - Size 1 - 10 holes - L112 mm
HTDPS1D	Olecranon plate - Standard - Right - Size 1 - 10 holes - L112 mm
HTGPS2D	Olecranon plate - Standard - Left - Size 2 - 13 holes - L153 mm
HTDPS2D	Olecranon plate - Standard - Right - Size 2 - 13 holes - L153 mm
HTGPS3D	Olecranon plate - Standard - Left - Size 3 - 16 holes - L194 mm
HTDPS3D	Olecranon plate - Standard - Right - Size 3 - 16 holes - L194 mm

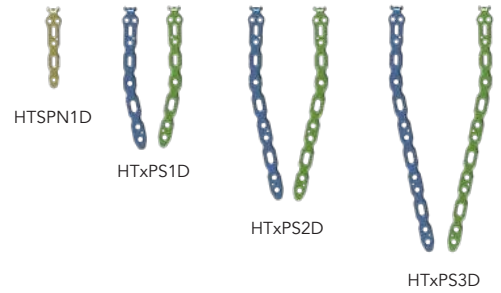

## Complex fractures plates

Ref.	Description
HTSEPS1D	Olecranon plate - Proximal - Standard - Symmetrical - Size 1 - 9 holes - L66 mm
HTGEPS2D	Olecranon plate - Proximal - Standard - Left - Size 2 - 12 holes - L114 mm
HTDEPS2D	Olecranon plate - Proximal - Standard - Right - Size 2 - 12 holes - L114 mm



### Reinforced core Ø2.8 mm locking screws\*

Ref.	Description
TDT2.8L10D to TDT2.8L40D	Ø2.8 mm reinforced core locking screw - L10 to 40 mm (2 mm incrementation)
TDT2.8L45D to TDT2.8L60D	Ø2.8 mm reinforced core locking screw - L45 to 60 mm (5 mm incrementation)

\*Turquoise green anodized



### Reinforced core Ø2.8 mm non locking screws\*

Ref.	Description
RDT2.8L10D to RDT2.8L40D	Ø2.8 mm reinforced core non-locking screw - L10 to 40 mm (2 mm incrementation)
RDT2.8L45D to RDT2.8L60D	Ø2.8 mm reinforced core non-locking screw - L45 mm to 60 mm (5 mm incrementation)

\*Yellow anodized



### Ø2.8 mm non locking screws\*

Ref.	Description
CT2.8L10D to CT2.8L40D	Ø2.8 mm non-locking screw - L10 to 40 mm (2 mm incrementation)
CT2.8L45D to CT2.8L60D	Ø2.8 mm non-locking screw - L45 to 60 mm (5 mm incrementation)

\*Light pink anodized



### Ø3.5 mm locking screws\*

Ref.	Description
SOT3.5LxxD	Ø3.5 mm locking screw Length: from 10 mm to 40 mm (2 mm incrementation)

\*Blue anodized



### Ø3.5 mm non locking screws\*

Ref.	Description
CT3.5LxxD	Ø3.5 mm non-locking screw Length: from 10 mm to 40 mm (2 mm incrementation)

\*Light blue anodized



**N.B:** Please note that all implants are also available in a sterile version. An "-ST" code is added at the end of the reference.  
Example: TDT2.8L10D-ST

# Instruments references.

#	Ref.	Description	Qty
1	ANC344	240 mm verbrugge forceps	1
2	ANC345	200 mm reduction forceps	1
3	ANC348	240 mm reduction forceps	1
4	ANC350	Ø4.5 mm AO quick coupling handle - Size 1	1
5	ANC351	Ø4.5 mm AO quick coupling handle - Size 2	1
6	ANC575	T8 quick coupling screwdriver	2
7	ANC650	Bending iron 1	1
8	ANC651	Bending iron 2	1
9	ANC1027	T15 AO quick coupling prehensor screwdriver	2
10	ANC1028	Length gauge for Ø3.5 mm screws	1
11	ANC102L	Length gauge for screw Ø2.8 mm - Measures 10 - 60 mm	1
12	ANC1030	Ø2.7 mm non threaded bent guide gauge for Ø3.5 mm screws	1

#	Ref.	Description	Qty
13	ANC1355	Ø2.7 mm quick coupling drill bit - L125 mm	2
14	ANC1428	Ø2.0 mm threaded long guide gauge for Ø2.8 mm screws	1
15	ANC1429	Ø2.0 mm threaded drill guide for Ø2.8 mm screws	2
16	ANC1430	Ø2.0 mm non threaded bent drill guide for Ø2.8 mm screws	1
17	ANC1431	Ø2.0 mm quick coupling drill bit - L 180 mm	2
18	ANC1432	Olecranon cutting guide	1
19	ANC1445	Ø2.7 mm threaded guide gauge for Ø3.5 mm screws	2
20	33.0216.210	Pin Ø1.6 - L210 mm	8
21	33.0220.210	Pin Ø2.0 - L210 mm	8

## REMOVAL KIT

If you have to remove Alians Elbow S implants, it is essential to order Newclip Technics removal sets :

- ANC350: Ø4.5 mm AO quick coupling handle - Size 1
- ANC351: Ø4.5 mm AO quick coupling handle - Size 2
- ANC575: T8 quick coupling screwdriver
- ANC974: T15 quick coupling screw driver

To remove any of the Alians Elbow S plates, first loosen all the screws without completely removing them (this prevents rotation of the plate when removing the last screw). Finally, completely remove all screws and the plate.

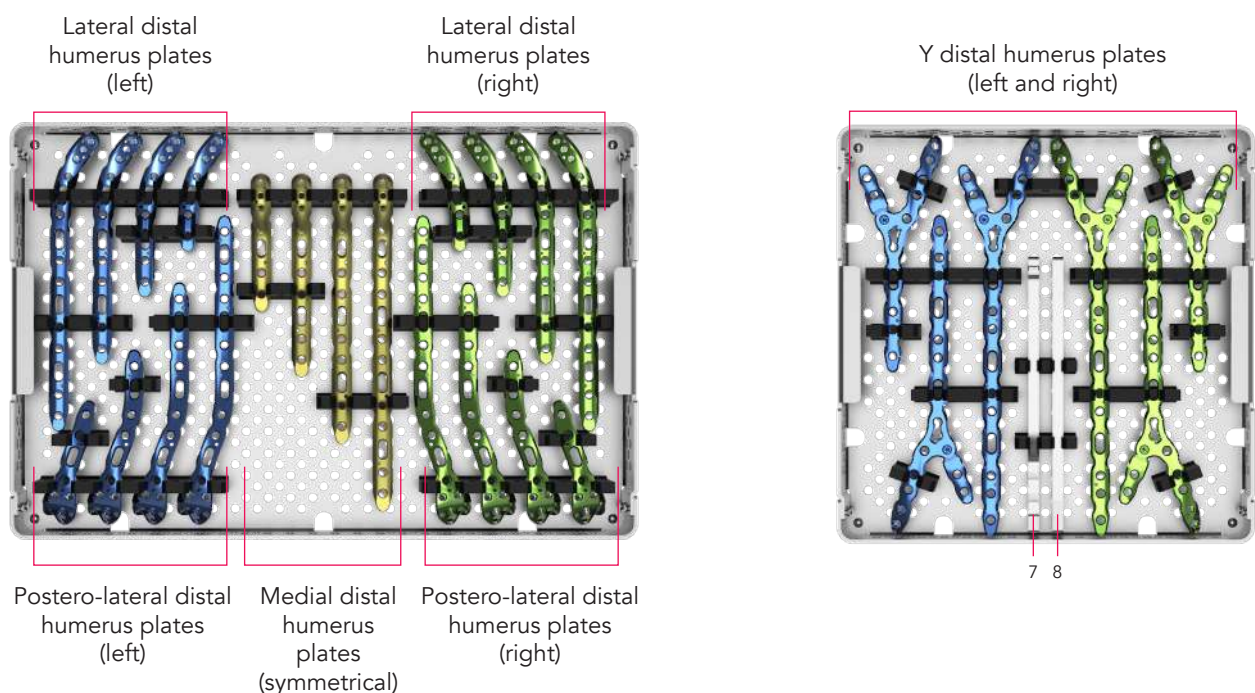

Olecranon plates - complex fractures

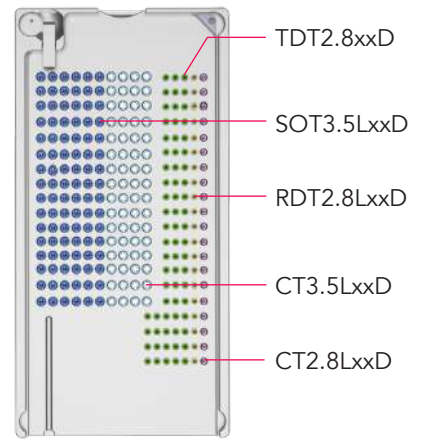
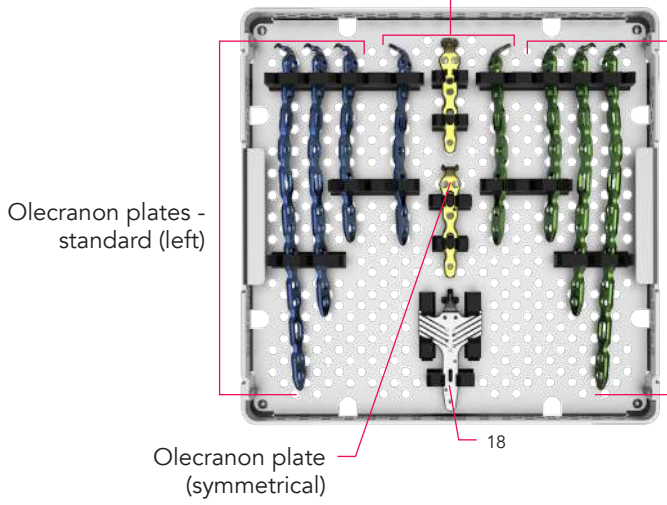

FOR Ø2.8 MM SCREWS

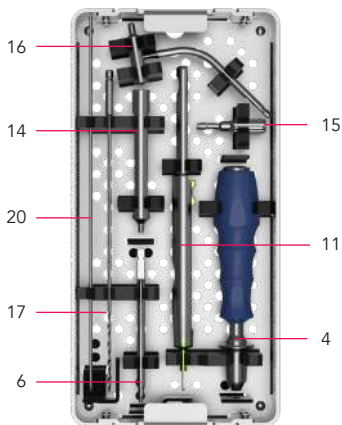

FOR Ø3.5 MM SCREWS

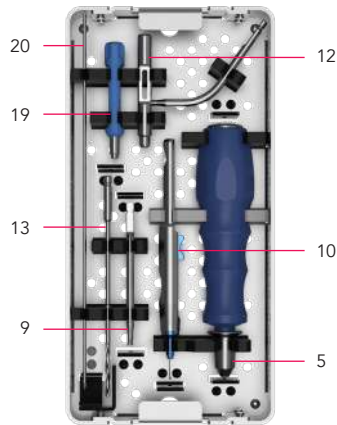

OPTIONAL

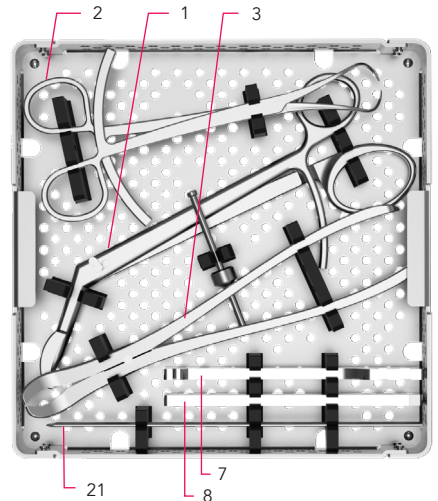
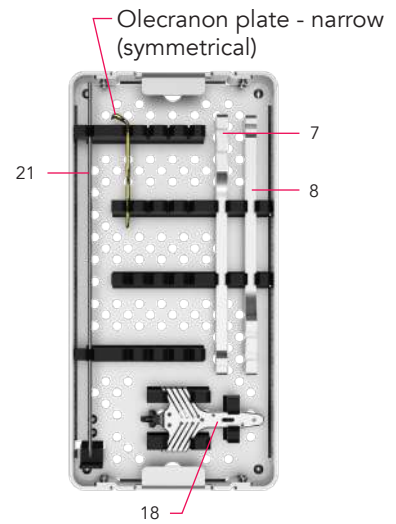

For more information, please refer to the Alians Elbow S Compo kit:



### PSI options

Ref.	Description
ANC042	Mini set - Base
ANC642	Opening wedge osteotomy instrument
ANC880	Ø1.9 mm pin for cutting guide - L30 mm
ANC995	Patient specific cutting guide for proximal ulna
ANC1040	Patient specific cutting guide for distal humerus osteotomy
ANC1218	Ø2.6 mm pin for cutting guide - L45 mm
ANC1219	Ø2.6 mm pin for cutting guide - L30 mm
33.0216.100	Pin Ø1.6 - L100 mm
33.0220.120	Pin Ø2.0 - L120 mm

### Additional PSI options

Ref.	Description
ANC956	Patient specific wedge
ANC1134	Patient specific cutting guide for iliac graft
ANC1135	Patient specific cutting guide for synthetic graft
ANC1184	Patient specific cutting guide for femoral head
ANC1224	Patient specific realignment guide
ANC1771	Ø1.6 mm holding plot



#### Compatible with patient-specific cutting guides (PSI)

Please contact your NEWCLIP TECHNICS representative if you have any questions about the availability of NEWCLIP TECHNICS products in your area.

This information is intended to demonstrate the Newclip Technics portfolio of medical devices. Always refer to the package insert, product label and/or user instructions including cleaning and sterilization before using any Newclip Technics product. These products must be handled and/or implanted by trained and qualified staff who have read the instructions before use. A surgeon must always rely on her or his own professional clinical judgement when deciding whether to use a particular product when treating a particular patient. Product availability is subject to the regulatory or medical practices that govern individual markets. Please contact your Newclip Technics representative if you have questions about the availability of Newclip Technics products in your area.

Manufacturer: Newclip Technics - Brochure EN - Alians Elbow S - Ed.6 - 04/2026 - Medical devices: class IIb - CE1639 SGS BE - Read labelling and instructions before the use of Newclip Technics medical devices. These products must be handled and/or implanted by trained and qualified staff who have read the instructions before use. Non-contractual pictures. Newclip Technics - 45 rue des Garottières - 44115 Haute Goulaine, France. Our subsidiaries: Newclip USA - Newclip Australia - Newclip GMBH - Newclip Japan - Newclip Iberia - Newclip Belgium.

# Containers references.

## Containers

Ref.	Description
ANC1433/C	Alians Elbow S set - Lid
ANC1433/M1	Alians Elbow S set - Module 1 - Distal humerus plates
ANC1433/M2	Alians Elbow S set - Module 2 - Distal humerus Y plates
ANC1433/M3	Alians Elbow S set - Module 3 - Olecranon plates
ANC1433/M4	Alians Elbow S set - Module 4 - Instrumentation for Ø2.8 mm screws
ANC1433/M5	Alians Elbow S set - Module 5 - Instrumentation for Ø3.5 mm screws
ANC1433/M6	Alians Elbow S set - Module 6 - General instrumentation
ANC1433/M7	Alians Elbow S set - Module 7 - Specific instrumentation
ANC1433/R1	Alians Elbow S set - Screw rack
ANC1434/B2	2 levels set - Base
ANC1434/B3	3 levels set - Base
ANC042	Mini set - Base
ANC042/CB	Mini set - Cambered lid



# Templates references.

Ref.	Description	Qty
ANC1457	Template for medial distal humerus plate - Symmetrical - Size 1 (NTSM1D)	1
ANC1458	Template for medial distal humerus plate - Symmetrical - Size 2 (NTSM2D)	1
ANC1459	Template for medial distal humerus plate - Symmetrical - Size 3 (NTSM3D)	1
ANC1460	Template for medial distal humerus plate - Symmetrical - Size 4 (NTSM4D)	1
ANC1461	Template for posterolateral distal humerus plate - Left - Size 1 (NTGQ1D)	1
ANC1462	Template for posterolateral distal humerus plate - Left - Size 2 (NTGQ2D)	1
ANC1463	Template for posterolateral distal humerus plate - Left - Size 3 (NTGQ3D)	1
ANC1464	Template for posterolateral distal humerus plate - Left - Size 4 (NTGQ4D)	1
ANC1465	Template for posterolateral distal humerus plate - Left - Size 5 (NTGQ5D)	1
ANC1466	Template for posterolateral distal humerus plate - Right - Size 1 (NTDQ1D)	1
ANC1467	Template for posterolateral distal humerus plate - Right - Size 2 (NTDQ2D)	1
ANC1468	Template for posterolateral distal humerus plate - Right - Size 3 (NTDQ3D)	1
ANC1469	Template for posterolateral distal humerus plate - Right - Size 4 (NTDQ4D)	1
ANC1470	Template for posterolateral distal humerus plate - Right - Size 5 (NTDQ5D)	1
ANC1471	Template for lateral distal humerus plate - Left - Size 1 (NTGL1D)	1
ANC1472	Template for lateral distal humerus plate - Left - Size 2 (NTGL2D)	1
ANC1473	Template for lateral distal humerus plate - Left - Size 3 (NTGL3D)	1
ANC1474	Template for lateral distal humerus plate - Left - Size 4 (NTGL4D)	1
ANC1475	Template for lateral distal humerus plate - Left - Size 5 (NTGL5D)	1
ANC1476	Template for lateral distal humerus plate - Right - Size 1 (NTDL1D)	1

Ref	Description	Qty
ANC1477	Template for lateral distal humerus plate - Right - Size 2 (NTDL2D)	1
ANC1478	Template for lateral distal humerus plate - Right - Size 3 (NTDL3D)	1
ANC1479	Template for lateral distal humerus plate - Right - Size 4 (NTDL4D)	1
ANC1480	Template for lateral distal humerus plate - Right - Size 5 (NTDL5D)	1
ANC1481	Template for Y distal humerus plate - Left - Size 1 (NTGY1D)	1
ANC1482	Template for Y distal humerus plate - Left - Size 2 (NTGY2D)	1
ANC1483	Template for Y distal humerus plate - Left - Size 3 (NTGY3D)	1
ANC1484	Template for Y distal humerus plate - Right - Size 1 (NTDY1D)	1
ANC1485	Template for Y distal humerus plate - Right - Size 2 (NTDY2D)	1
ANC1486	Template for Y distal humerus plate - Right - Size 3 (NTDY3D)	1
ANC1487	Template for olecranon plate - Standard - Left - Size 1 (HTGPS1D)	1
ANC1488	Template for olecranon plate - Standard - Left - Size 2 (HTGPS2D)	1
ANC1489	Template for olecranon plate - Standard - Left - Size 3 (HTGPS3D)	1
ANC1490	Template for olecranon plate - Standard - Right - Size 1 (HTDPS1D)	1
ANC1491	Template for olecranon plate - Standard - Right - Size 2 (HTDPS2D)	1
ANC1492	Template for olecranon plate - Standard - Right - Size 3 (HTDPS3D)	1
ANC1493	Template for olecranon plate - Narrow - Symmetrical - Size 1 (HTSPN1D)	1
ANC1719	Template for olecranon plate - Proximal - Standard - Symmetrical - Size 1 (HTSEPS1D)	1
ANC1720	Template for olecranon plate - Proximal - Standard - Left - Size 2 (HTGEPS2D)	1
ANC1721	Template for olecranon plate - Proximal - Standard - Right - Size 2 (HTDEPS2D)	1

[newcliptechnics.com](http://newcliptechnics.com)

