

INAXIS.

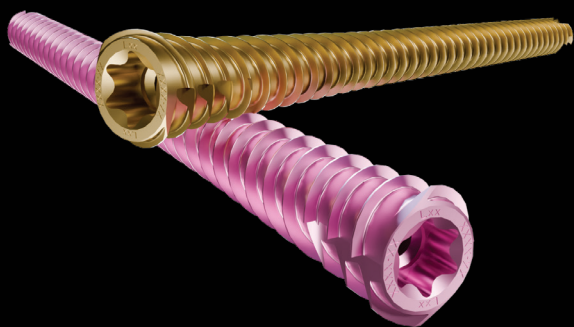

NEUTRALIZATION
EXTREMITY
SCREWS





INAXIS.

Ø3.0 AND Ø4.0 SCREWS

Intended purpose:

The Initial S™ single use sterile kits consist of a set of instruments or a set of instruments and implants (washers) to be used only in trauma or orthopaedic surgery, when Newclip Technics screws for osteosynthesis are fitted. The implants of the Stand Alone Screws range are intended for adults with fractures and/or congenital or post-traumatic or degenerative deformities of the bones.

Contraindications:

- Pregnancy.
- Acute or chronic local or systemic infections.
- Allergy to one of the materials used or sensitivity to foreign bodies.

Technical features.

SCREWS FEATURES

NEUTRALIZATION EXTREMITY SCREWS

- **Ø1.3mm cannulated screws** for a guided placement.
- **Non-compression design** avoids shortening in transverse, oblique or spiral fractures.
- **Self-drilling**: the shape of the distal tip of the screws allows self-drilling properties.
- **Self-tapping**: the tip and the head of the screws have been designed with self-tapping shape allowing an insertion of the screw without any need of pre-tapping step.
- **Double thread**: fast lead for surgical efficiency.
- **Evolutive diameter** to maximize the anchorage in the cortical and optimize filing of the Isthmus.
- **Hexalobular stamp**.

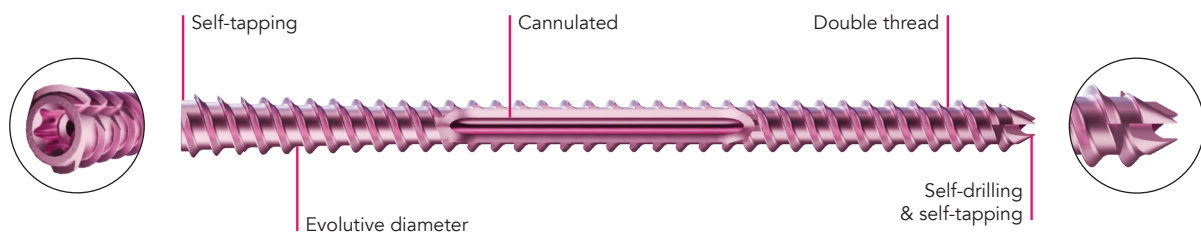

INSTRUMENTS FEATURES

ONE UNIQUE INSTRUMENTATION FOR BOTH DIAMETERS

- Dedicated **drill bit** corresponding to the screw diameter⁽¹⁾.
- **Length gauge** with tip for correct screw size selection according to the isthmus diameter⁽²⁾.
- **Cannulated screwdriver** with hexalobular stamp, compatible with power tool or handle⁽³⁾.

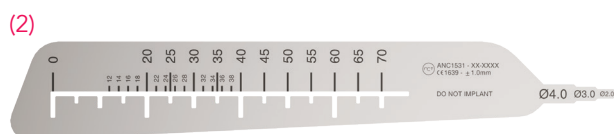
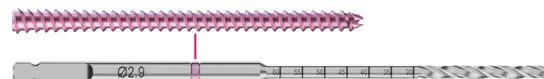
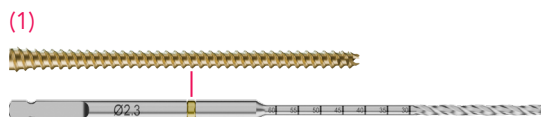

Surgical technique.

METACARPAL FRACTURE

Example of a surgical technique for metacarpal fracture fixation using a $\varnothing 4.0$ mm neutralization screw (H1.3GLT4.0LxD). This technique is applicable for all diameter and type of screws of the range.

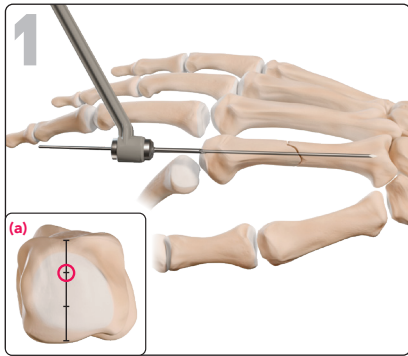

Position the double guide, then, insert the pin through the pin guide until the desired depth is reached.

Remove the double guide.

N.B: The pin guide entry point should be in the dorsal third of the metacarpal head^(a).



Position the extremity of the length gauge on the isthmus to determine the screw diameter.

N.B: A fluoroscopy can be performed to determine the screw diameter by comparing it with the shaped widths.

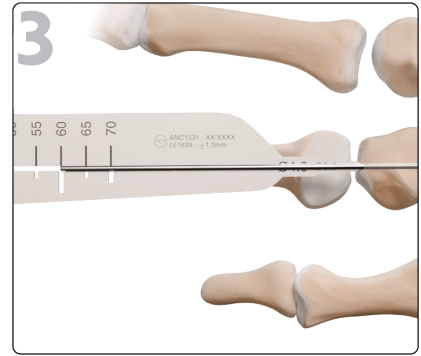

Hold the length gauge against the pin and the cortex.

Read the insertion depth at the rear of the pin.

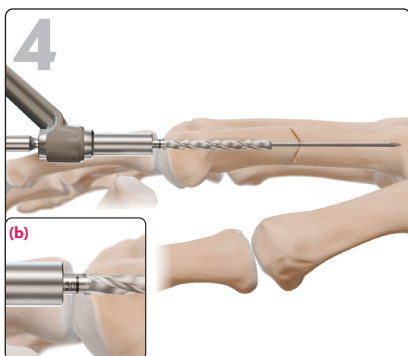

Select the drill bit corresponding to the screw diameter (same color code).

To prevent the pin removal during the drilling step, drill up to the isthmus through the protection sleeve of the double guide.

N.B: The drilling depth can be checked using the marking on the drill, at the rear of the cortex^(b).

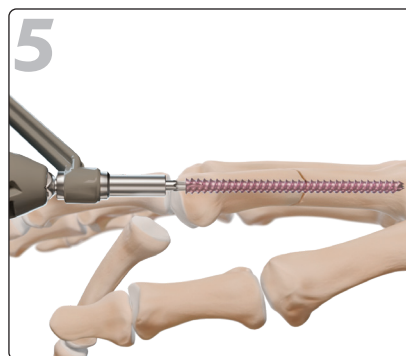

Select the appropriate screw determined in steps 2 and 3.

By using the screwdriver, insert the screw along the pin through the protection sleeve of the double guide until the screw head is buried. Final tightening of the screw must be performed by hand.

Then, remove the pin and the double guide.

FINAL RESULT.

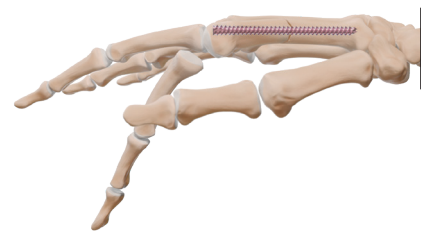

Screws references.

Neutralization extremity screws*

Ref.	Description
H1.3GLT3.0L25D-ST to H1.3GLT3.0L70D-ST	Ø3.0 mm neutralization extremity screw** - cannula Ø1.3 - full thread - L25 to 70 mm - STERILE - 5mm increments
H1.3GLT4.0L25D-ST to H1.3GLT4.0L70D-ST	Ø4.0 mm neutralization extremity screw*** - cannula Ø1.3 - full thread - L25 to 70 mm - STERILE - 5mm increments

*Only available in sterile
 **Gold anodized
 ***Pink anodized

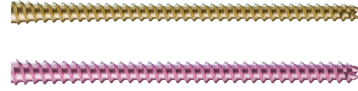

Instruments references.

Inaxis sterile kit*

#	Ref.	Description
01	KIT-SCE3.0-4.0H	Instrumentation kit for Ø3.0 mm and Ø4.0 mm cannulated extremity screws - Hand

*The same kit will be used for the removal.



Instrumentation content

#	Description	Qty
02	Single use handle	1
03	T10 prehensor quick coupling screwdriver - cannulated Ø1.3 mm	1
04	Ø2.3 mm quick coupling drill bit - cannula Ø1.3 mm - L120 mm	1
05	Ø2.9 mm quick coupling drill bit - cannula Ø1.3 mm - L120 mm	1
06	Double guide - Ø1.3 mm pin guide / soft tissues protection sleeve for extremity screws	1
07	Length gauge for pin L120 mm / template for extremity screws**	1
08	Pin Ø1.2 mm - L120 mm***	3

**Also available alone in sterile packaging with the reference "ANC1531-ST"
 ***Also available alone in sterile packaging with the reference "ANC1570-ST"

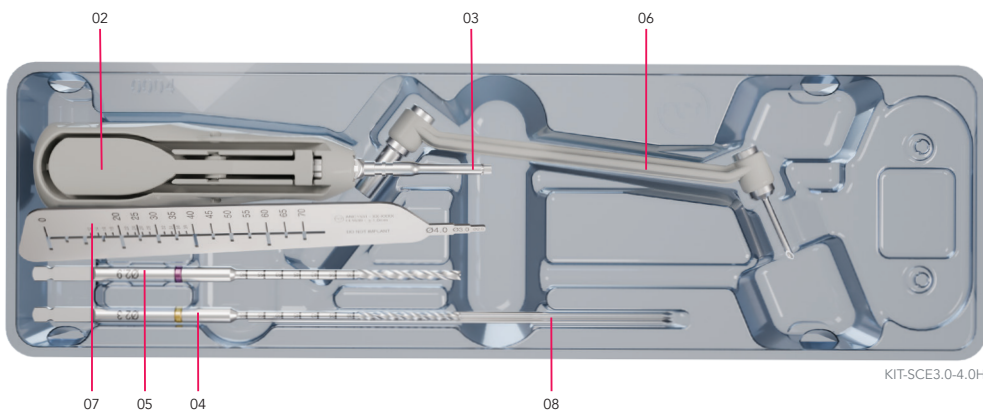

This information is intended to demonstrate the Newclip Technics portfolio of medical devices. Always refer to the package insert, product label and/or user instructions including cleaning and sterilization before using any Newclip Technics product. These products must be handled and/or implanted by trained and qualified staff who have read the instructions before use. A surgeon must always rely on her or his own professional clinical judgement when deciding whether to use a particular product when treating a particular patient. Product availability is subject to the regulatory or medical practices that govern individual markets. Please contact your Newclip Technics representative if you have questions about the availability of Newclip Technics products in your area.

Manufacturer: Newclip Technics - Brochure EN - Inaxis - Ed.1 - 12/2024 - Medical devices: class IIb - CE1639 SGS BE - Read labelling and instructions before the use of Newclip Technics medical devices. These products must be handled and/or implanted by trained and qualified staff who have read the instructions before use. Non-contractual pictures.
 Newclip Technics - 45 rue des Garottières - 44115 Haute Goulaine, France. Our subsidiaries: Newclip USA - Newclip Australia - Newclip GMBH - Newclip Japan - Newclip Iberia - Newclip Belgium.

newcliptechnics.com

